

# **RHPC-HD10**

## **(DCC-SC01HD32)**

### **Color HD(720P) Board Camera**



## **Product Specification**

## **& Operational Manual**

 **OemCameras.com**

Phone - 1-888-919-2263

International - +1-845-343-4077

Fax - +1-845-343-4299

Email - [support@oemcameras.com](mailto:support@oemcameras.com)

## Table of Contents

	PAGE
1. Scope of Application .....	2
2. Handling Precautions .....	2
3. Product Outline .....	3
4. Bundled Items.....	3
4.1. StandardBundled Items.....	3
4.2. Optional Items .....	3
5. Specifications.....	4
5.1. General Specifications .....	4
5.2. Camera Input/Output Signals .....	5
6. Part Names and Functions .....	6
7. External Connector Pin Assignment .....	7
7.1. Power Input and Signal Output Connectors (Harness 2050) .....	7
7.2. OSD Switch Connectors (Harness SC01OSD) ※Optional Connectors.....	8
7.3. Remote Control Cable Connectors.....	8
8. Camera Operating Instructions.....	9
8.1. Switch Operation without OSD Menu .....	9
8.2. PC Operation via RS232C.....	9
8.3. Switch Operation with OSD Menu .....	9
9. Factory Settings (Underlined and Bold letters show the factory settings).....	15
10. Dimensions .....	16
11. Cases for Indemnity (Limited Warranty) .....	17
12. CMOS Pixel Defect.....	17
13. Product Support.....	17

## 1. Scope of Application

This is to describe DCC-SC01HD32, analog color HD (720P) board camera assembly.  
All specifications contained herein are subject to change without prior notice.  
Reproduction in whole or in part is prohibited.

## 2. Handling Precautions

The camera assembly must not be used for any nuclear equipments or aerospace equipments with which mechanical failure or malfunction could result in serious bodily injury or loss of human life. Our warranty does not apply to damages or defects caused by irregular and/or abnormal use of the product.

Please observe all warnings and cautions stated below.

Our warranty does not apply to damages or malfunctions caused by neglecting these precautions.

- Do not directly touch the board camera while camera is in operation. The board camera can be very hot and you may burn yourself.
- Do not apply excessive voltage. (Use only the specified voltage.) Unstable or improper power supply voltage may cause damages or malfunction of the camera.
- Do not directly touch the optical surface. CMOS image sensor is fragile.
- Do not use or store the camera assembly in the dusty or humid places.
- Do not apply excessive force or static electricity that could damage the camera assembly.
- In some cases, hunting may occur when using electric iris, depending on the object to shoot.
- In some cases, color may change under fluorescent lamp when using electric iris.
- Do not shoot direct images that are extremely bright (e.g., light source, sun, etc). When the camera is not in use, please put the protection cap on.
- Follow the instructions in Chapter 7, "External Connector Pin Assignment" for connecting the camera. Improper connection may cause damages not only to the camera but also to the connected devices.

In case of abnormal operation, contact the distributor from whom you purchased the product.

### 3. Product Outline

DCC-SC01HD32 is a HD (720P) output, color board camera assembly utilizing 1/3 type CMOS image sensor. With our own image processing technologies, electrical zoom, long time exposure function, OSD functions, and others are incorporated into the camera.

32x32 + 42x42 (2 boards) in size should best match for embedded systems.

HD 720p/60, 720p/59.94, 720p/50 analog component (Y/Pb/Pr) and RGB outout available.

#### Key Features

- Long time exposure shutter function enables to capture clear images even under low illumination.
- On Screen (OSD) function enables to set camera settings by menu. (OSD operational switch needed).
- Camera settings can be set with RS 232C via PC. (Dedicated remote control unit needed).

### 4. Bundled Items

#### 4.1. Standard Bundled Items

- Board Camera
- Harness 2050: For power supply and video signal output. (10pins connector, 10 cores)
- Camera attachment screws (4pcs)
- Protection cap or seal (With optional lens, protection cap will be inclosed. Without optional lens, protection seal will be inclosed.)

#### 4.2. Optional Items

- Dedicated lens
- Harness SC01OSD: For OSD switch connection. (10pins connector, 5 cores)
- RE-300A: Remote control cable (Between camera and PC)

## 5. Specifications

## 5.1. General Specifications

(1) Pick up device	Device Type	1/3 type CMOS	SONY	IMX035LQR-C
	Effective Pixel Numbers	1329(H) × 1049(V)		
	Unit Cell Size	3.63μm(H) × 3.63μm(V)		
	Chip Size	7.64mm(H) × 7.64mm(V)		
(2) Resolutions	1280(H) × 720(V)			
(3) Aspect Ratio	16 : 9			
(4) Video output frequency	60fps	Horizontal Frequency	45 kHz	
		Vertical Frequency	60 Hz	
	59.94fps	Horizontal Frequency	44.95 kHz	
		Vertical Frequency	59.94 Hz	
	50fps	Horizontal Frequency	37.50 kHz	
		Vertical Frequency	50 Hz	
(5) Sync. system	Internal sync			
(6) Video output standard	Analog Component Output : Y/Pb/Pr 1Vp-p (3 Values, Sync signals)			75Ωterminal
	RGB Output : RGB 1Vp-p (without SYNC) 75Ω terminal HD, VD TTL level (over 2.1V 1kΩ terminal)			
(7) Horizontal resolution	600TV lines (contour correction SHARP)			
(8) Sensitivity	F4.0 2000lx			
(9) Minimum illumination	60fps,59.94fps :	F2.5	6.0lx (with dedicated board camera lens)	
		F1.4	3.0lx (with F1.4 lens)	
	50fps :	F2.5	5.0lx (with dedicated board camera lens)	
		F1.4	2.5lx (with F1.4 lens)	
	Conditions : VIDEO 50%, AGC 36dB, Electrical Shutter OFF			
(10) Dust or stains in optical systems	No dust or stain shall be detected on the testing screen with dedicated lens installed, or with setting the camera aperture at F16 if there is no lens.			
(11) Power requirements	DC+9~+15V			
(12) Power consumption	2.0W (Max. 2.4 W) at DC+12V IN			
(13) Dimension	Refer to overall dimension drawing.			
(14) Mass	Approx. 45g (including optional dedicated lens).			
(15) Lens Mount	Dedicated board camera lens mouont. ※Refer to overall dimension drawing.			
(16) Gain Setting	AGC (Max gain : +18dB, +24dB, +30dB, +36dB), AGC OFF(0dB)			
	MANUAL : 0dB~36dB			
(17) Shutter Speed Variable Range	OFF : 1/60(60fps, 59.94fps), 1/50(50fps)			
	FL : 1/100(60fps, 59.94fps), 1/120(50fps)			
	MANUAL : 1/10k, 1/4k, 1/2k, 1/1k, 1/500, 1/250, 1/120, 1/100, 1/60, 1/50, 1/30, 1/25, 1/15, 1/8, 1/4, 1/2, 1s, 2s, 4s, 8s			
	AUTO : 1/10ks~8s (Upper or lower limit can be set.)			
(18) White Balance Adjustment Range	ATW1 : 2200~9000K, ATW2 : 3200~6500K			
	Preset:3200K, 4800K, 6500K, Manual: 2200~9000K			
(19) Electrical Zoom	×1~×4 PAN, TILT			
(20) AUTO IRIS Signals	Responses are adjustable.			
	Usable with electrical shutter (with priority to electrical shutter).			

(21) Back Light	Devided into 49 screens (7x7), and each screen can be individually masked. (Masked part shall be ignored.) The same settings are applicable to ATW.
(22) Character Display	Character Display: alphanumeric characters and symbols (Max 24 letters) Display Position: The upper left portion of the screen (fixed) Characters can be edited by OSD.
(23) Contour Correction	SHARP/STD./SOFT selectable.
(24) Chromaticness Adjustment	Chromaticness is adjustable. 255(typ.)~0(B/W)
(25) Gamma Compensation	Gamma is adjustable. $\gamma=0.45\sim1.0$ Data (127~0)
(26) Pixel Defect (White Spot) Correction	OFF/ON (Initial Setting) / ON (User Setting) Maximum correction value: 63 values (Depending on conditions.) Maximum correction value and detecion start level can be set. ※When correction is started after blocking light, long time exposure and AGC is set automatically to start.
(27) Remote Control Operation	Operatable via RS232C. 9600bps(typ), with no parity, stop pit: 1bit Communication speed selection : 2400, 4800, 9600, 19200 bps
(28) Safety/Quality standards	UL: Conform to UL Standard including materials and others. CE: Emission: EN55022:2006(Class B) Immunity: EN55024:1998/A1:2001/A2:2003 RoHS: Conform to RoHS
(29) Operational environment	Specifications guaranteed 0 ~ +40°C Humidity: 20 ~ 80%RH with no condensation Operation guaranteed -5 ~ +45°C Humidity: 20 ~ 80%RH with no condensation
(30) Storage environment	Temperature : -25 ~ +60°C Humidity: 20 ~ 80%RH with no condensation.

## 5.2. Camera Input/Output Signals

Video Signals	White clip level: 760mV $\pm$ 10% SYNC level: 300mV $\pm$ 10% (3values sync signals)
---------------	---

## 6. Part Names and Functions

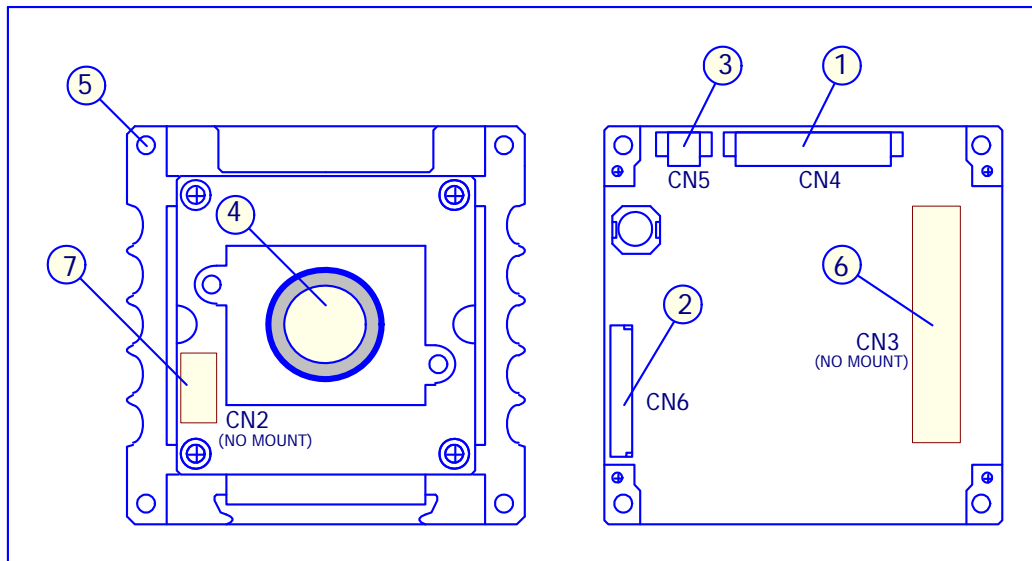

- ① Power Input and Video Output  
With the bundled harness, power input and video output signals are connected to a monitor. Please refer to Chapter 7, "External connector pin assignment".
- ② OSD Operational Switch Connector  
With the optional harness, OSD operational switch is connected. Please refer to Chapter 7, "External connector pin assignment".
- ③ Remote Control Connector  
Optional remote control cable (RE-300A) is connected.  
With connecting the remote control cable (RE-300A) to a PC, serial communication via RS-232C is valid. Please refer to the other materials for the communication details. (To be prepared)
- ④ Dedicated board camera lens  
Lenses are optional.
- ⑤ Camera Mounting Holes  
With bundled attachment screws, mount the camera.
- ⑥ Extended Connectors (Not implemented. Can be implemented on request.)
- ⑦ DC IRIS Connectors (Not implemented. Can be implemented on request.)

7. External Connector Pin Assignment

7.1. Power Input and Signal Output Connectors (Harness 2050)

Connectors of camera side	Connectors of bundled harness side
53398-1090 (molex)	51021-1000 (molex)

CN4	Signals	Component Output	RGB Output
1	Pb/B OUT	Pb output (3values SYNC)	BLUE output (without SYNC)
2	Pr /R OUT	Pr output (3values SYNC)	RED output (without SYNC)
3	IRIS OUT	Video Iris signals	←
4	HD OUT	HD output	←
5	GND	GND (for video signals)	←
6	VD OUT	VD output	←
7	GND	GND (for video signals)	←
8	Y/G OUT	Y output (3values SYNC)	GREEN output (without SYNC)
9	GND	GND (Power)	←
10	POWER	Power Input (DC+12V)	←

Connection for Component Y/Pb/Pr output

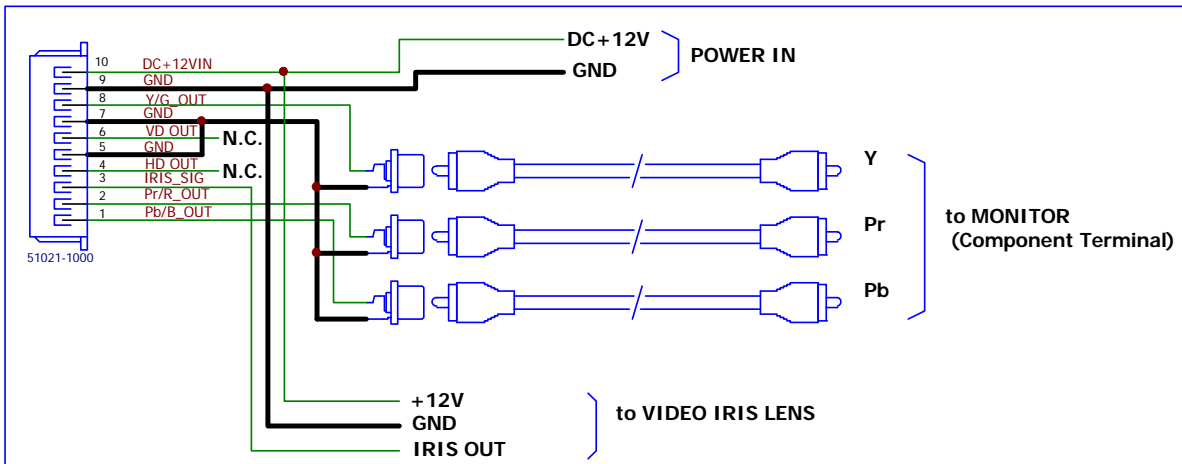

Connection for RGB output

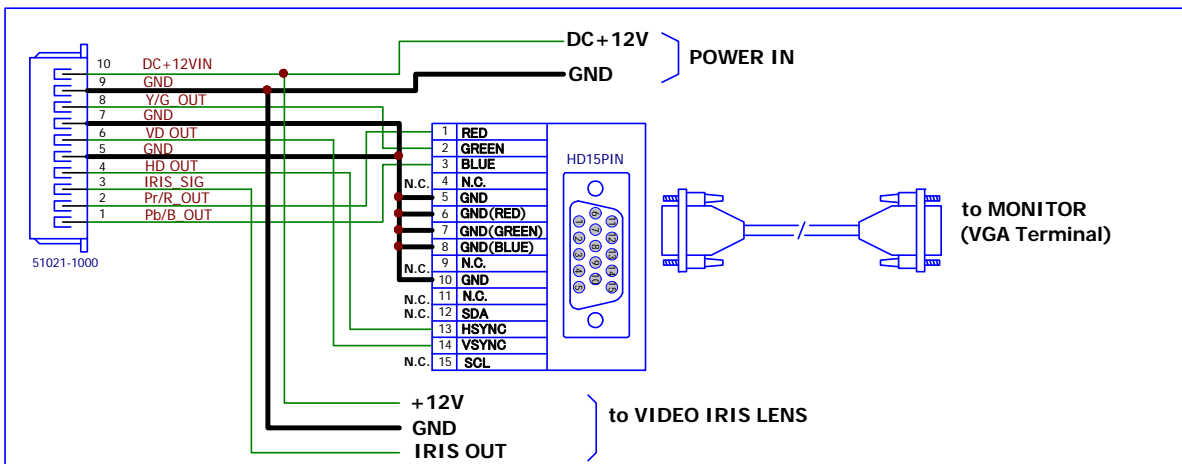



7.2. OSD Switch Connectors (Harness SC01OSD) ※Optional Connectors

Connectors of camera side	Connectors of optional harness side
BM10B-SRSS (NICHATSU)	SHR-10V-S-B (NICHATSU)

CN6	Signals	
1	N.A.	(OPEN)
2	N.A.	(OPEN)
3	N.A.	(OPEN)
4	N.A.	(OPEN)
5	N.A.	(OPEN)
6	GND	GND for switch connection
7	SW_BACK	Switch connecting terminal (BACK)
8	SW_UP	Switch connecting terminal (UP)
9	SW_ENTER	Switch connecting terminal (ENTER)
10	SW_DOWN	Switch connecting terminal (DOWN)

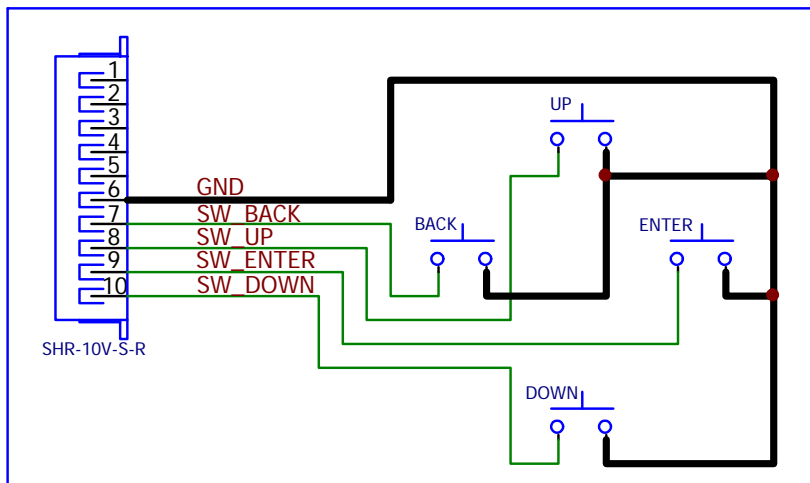

7.3. Remote Control Cable Connectors

Connectors of camera side	Connectors of remote control cable side
53398-0271 (molex)	51021-0200 (molex)

CN6	Signals	
1	GND	Remote Control GND
2	REMOTE	Remote Control Signals (Input/Output)

## 8. Camera Operating Instructions

There are 3 different operating methods, operating with OSD menu, operating without OSD menu, and operating via PC with dedicated remote control cable connected to the remote control terminals. Depending on its operating methods, selectable camera settings are different. Please refer to the selectable settings by each operational method as below.

### 8.1. Switch Operation without OSD Menu

#### Operational Functions

EZOOM, PAN, TILT, and Video Format Selection

#### EZOOM Operation

EZOOM can be operated with [UP] KEY and [DOWN] KEY.

With [DOWN] KEY, it goes to TELE side, and with [UP] KEY, it goes to WIDE side.

Except when EZOOM is x1.00, it goes to EZOOM→PAN→TILT→EZOOM everytime when [BACK] KEY is pushed. PAN and TILT values can be set as well.

\* When EZOOM is x1.00, PAN and TILT will automatically go back to the center of the image.

#### Display Format Selection

Video format can be changed as follows, pushing [ENTER] KEY while pushing [BACK] KEY.

720p/60 Y/PbPr → 720p/59.94 Y/PbPr → 720p/50 Y/Pb/Pr →

720p/60 RGB → 720p/59.94 RGB → 720p/50 RGB → 720p/60 Y/Pb/Pr

\* The selected settings with operations explained the above can not be saved as they are.

To save those settings, EXIT→SAVE shall be done by OSD displayed operation.

\* Initial setting is 720p/59.94 Y/Pb/Pr.

### 8.2. PC Operation via RS232C

Camera can be controlled via a PC using camera control software, with dedicated remote control cable (RE-300A) connected to the remote control terminal.

### 8.3. Switch Operation with OSD Menu

[ENTER] KEY: To enter into the menu with pushing this button for long.

In the menu, this button works to go to the next menu, and works as [→] KEY.

[BACK] KEY: In the menu, this button works to go back to the prior menu, and works as [←] KEY.

[UP] KEY: To select items in the menu.

When operating volume type menu, this button makes the value to +direction.

[DOWN] KEY: To select items in the menu.

When operating volume type menu, this button makes the value to -direction.

Main Menu			
Items	SELECT	Next menu	Explanation
GAIN	OFF		Set AGC OFF to make Gain 0dB.
	AGC>	→MAX GAIN	Set AGC ON. [ENTER] to go to the next menu to enable to set the maximum Gain.
	MANUAL>	→MANUAL GAIN	Set Gain manually. [ENTER] to go to the next menu to enable to set the manual value.
SHUTTER	OFF		Set the electronic shutter OFF. The same shutter speed set as frame rate will be set.
	FL		Set to be flickerless. When the set frame rate is 60fps, and 59.94fps, 1/100s shutter speed will be set, while the set frame rate is 50fps, 1/120s shutter speed will be set.
	AES>	→AES SETTING	Operate Auto electronic shutter. [ENTER] to go to the next menu to enable LOW SHUTT, LIM (limitation of electronic high sensitivity), and HIGH SHUTT LIM (limitation of high speed electronic shutter).
	MANUAL>	→MANUAL SHUTTER	Set the electronic shutter manually. [ENTER] to go to the next menu to enable to set the manual value.
WHITE_BAL	ATW>	→ATW SETTING	Operate Auto White Balance. [ENTER] to go to the next menu to enable to set tracking range, tracking speed, and OFF SET of convergent point.
	3200K		Fix white balance to 3200K.
	4800K		Fix white balance to 4800K.
	6500K		Fix white balance to 6500K.
	MWB>	→MANUAL WHITE BAL	Set White Balance manually. [ENTER] to go to the next menu to enable to set the manual value.
AESET	LEVEL>	→AE LEVEL	[ENTER] to go to the next menu to enable to set the blightness of auto exposure.
	RESPONS>	→AE RESPONS	[ENTER] to go to the next menu to enable to set the operational speeds of AGC, AES, and Auto Iris. Volume adjustment of Video Iris can be checked as well.
	BLC>	→BLC SETTING	[ENTER] to go to the next menu to enable to set back light setting.
OPTION	PICTURE>	→PICTURE	[ENTER] to go to the next menu to enable to set the image sharpness, gamma compensation, saturation, and defective pixel correction of the image sensor.
	EZOOM>	→EZOOM	[ENTER] to go to the next menu to enable to set electronic shutter.
	DISPLAY>	→DISPLAY	[ENTER] to go to the next menu to enable to set the display settings of title indication and electronic zoom magnifications.
	REMOTE>	→REMOTE SETTING	[ENTER] to go to the next menu to enable to set the serial communication speed.
EXIT	SAVE>	END	Save the data set with OSD, and terminate the menu.
	CANSEL>	END	Restore the data set with OSD, and terminate the menu.
	DEFAULT>	END	Restore the data to the initial settings, and terminate the menu.

MAX GAIN			
Items	SELECT	Next menu	Explanation
MAX GAIN	18dB		Set the maximum gain of AGC.
	24dB		
	30dB		
	36dB		

MANUAL GAIN			
Items	SELECT	Next menu	Explanation
MANUAL GAIN	0dB-36dB		Set the manual gain.

AES SETTING			
Items	SELECT	Next menu	Explanation
LOW SHUTT.LIM	8s,4s,2s,1s, 1/2,1/4,1/8, 1/15,1/25, 1/30,1/50, 1/60,1/100, 1/120,1/250, 1/500,1/1K, 1/2K,1/4K, 1/10K		Limit the low speed limitation of electronic shutter auto. Higher speed than HIGH SHUTT.LIM. can't be set.
HIGH SHUTT.LIM	8s,4s,2s,1s, 1/2,1/4,1/8, 1/15,1/25, 1/30,1/50, 1/60,1/100, 1/120,1/250, 1/500,1/1K, 1/2K,1/4K, 1/10K		Limit the high speed limitation of electronic shutter auto. Lower speed than LOW SHUTT.LIM. can't be set.

MANUAL SHUTTER			
Items	SELECT	Next menu	Explanation
SHUTTER SPEED	8s,4s,2s,1s, 1/2,1/4,1/8, 1/15,1/25, 1/30,1/50, 1/60,1/100, 1/120,1/250, 1/500,1/1K, 1/2K,1/4K, 1/10K		Set the shutter speed manually.

ATW SETTING			
Items	SELECT	Next menu	Explanation
ATW RANGE	ATW1		Set the ATW range to 2200~9000K.
	ATW2		Set the ATW range to 3200~6500K.
ATW RES	SLOW		Set the speed of ATW.
	MID.		
	FAST		
R OFFSET	0-255		Adjust R offset value of ATW White standard.
B OFFSET	0-255		Adjust B offset value of ATW White standard.

MANUAL WHITE BAL.			
Items	SELECT	Next menu	Explanation
ONE PUSH	END		One push to set the manual white balance value automatically. [D]: to go to END->CAL to start detection. With completion, it goes to CAL->END and its results are reflected in RED GAIN and in BLUE GAIN. R/B OFFSET of ATW SETTING is to be reflected.
	CAL.		
RED GAIN	0-255		Gain adjustment of RED.
BLUE GAIN	0-255		Gain adjustment of BLUE.

AE LEVEL			
Items	SELECT	Next menu	Explanation
AE LEVEL	0-127		Set the AE level. Operate AGC, AES, and Auto Iris settings.

AE RESPONS			
Items	SELECT	Next menu	Explanation
AGC RES.	0-255		Set the response speed of AGC. The bigger the value goes, the slower the speed will be.
AES RES.	0-255		Set the response speed of AES. The bigger the value goes, the slower the speed will be.
IRIS RES.	0-255		Set the response speed of Auto Iris. The bigger the value goes, the slower the speed will be. ※Hunting may occur if the speed is too fast.
IRIS LEVEL	0-127		Set Video Iris typed Auto Iris lens. Please refer to the usage method of Auto Iris lens.

BLC SETTING			
Items	SELECT	Next menu	Explanation
BLC SETTING	OFF		OFF back light. (Full Photometry)
	ON(3×3)		ON back light. (Center 3×3)
	ON(USER) >	→BLC WINDOW SET	ON back light. With the next menu, window settings can be done.

PICTURE			
Items	SELECT	Next menu	Explanation
SHARPNESS	SOFT		Set the sharpness.
	STD.		
	SHARP		
GAMMA	0-127		Set gamma. (Data 127: $\gamma \approx 0.45$ )
CHROMA	0-255		Set chromaticness. Data 0: B/W
BLEMISH COMP.	OFF		OFF pixel defect correction of image sensor (White spot).
	USER>	→BLEMISH COMP.	ON pixel defect correction of image sensor (White spot) by user setting. [ENTER] to go to the next menu to enable to correct blemish by user settings.
	FACT.		ON pixel defect correction of image sensor (White spot) by factory setting.

EZOOM			
Items	SELECT	Next menu	Explanation
EZOOM	×1-×4		Set magnification of electronic zoom.
PAN	0-255		When magnification ratio is more than x1, video output range can be horizontally shifted. When magnification ratio is x1, PAN value becomes 128 and the video output range will return to the center.
TILT	0-255		When magnification ratio is more than x1, video output range can be vertically shifted. When magnification ratio is x1, PAN value becomes 128 and the video output range will return to the center.

DISPLAY			
Items	SELECT	Next menu	Explanation
TITLE	OFF		OFF the display of title indication.
	CHAR>	→CAM TITLE EDIT	ON the display of the title indication. Alphanumeric characters and symbols can be displayed. [ENTER] to go to the next menu to enable to edit.
MODE	OFF		OFF the video format indication and electronic zoom indication when the menu is undisplayed.
	ON		ON the video format indication and electronic zoom indication when the menu is undisplayed. When video format is changed, it is indicated and disappears automatically after approx. 10 seconds. When PAN, TILT, and EZOOM are changed, it is indicated and disappears automatically after approx. 5 seconds.

REMOTE SETTING			
Items	SELECT	Next menu	Explanation
BIT RATE	19200bps		Set the speed of serial communication.
	9600bps		
	4800bps		
	2400bps		

BLC WINDOW SET			
Items	SELECT	Next menu	Explanation
7x7(49) Window MASK SET/CLR	window0~ window48		Set Mask ON/OFF for back light. The masked area (whiteout part) will not be reflected by auto exposure. [D]: to MASK ON and goes to the next area. [U]: to MASK OFF and goes to the next area.

BLEMISH COMP.			
Items	SELECT	Next menu	Explanation
USER COMP.	DISP.		Indicate the corrected are by pixel defect correction (White spot) with blinking.
	START		Start detection of pixel defect area (White spot) with sheilding and blacking-out the entire lens. With successfully completed, transmit to DISP and display the area to be corrected with blinking. If not successfully completed, transmit to ERROR.
	ERROR		If not shielded or max q'ty is too low, ERROR might occur. In such case, shiled completely and increase the max q'ty to restart.
START LEVEL	16-127		Set the beginning level to start detection. The level will go higher gradually from this level.
MAX. QTY	4-63		Set the maximum q'ty to detect. The q'ty to be detected shall be less than this q'ty. If there are too many areas to be corrected, reduce this q'ty.

CAM TITLE EDIT			
Items	SELECT	Next menu	Explanation
Character Selection	ABCDEFGH IJKLMNOP QRSTUVW XYZ abcdefghijk lmnopqrstu vwxyz-.,()0 123456789		[U], [D] to select characters, and [ENTER] to shift the character position to edit to the right.

### Usage Method of Auto Iris Lens

This camera outputs signals for auto iris so that Video Iris lenses can be connected.  
Here, we would like to explain how to adjust variable resister installed in the Video Iris lenses.  
Please refer to the Section 7, External Connector Pin Assignment, for connection.

First of all, set GAIN OFF and SHUTTER OFF, then set AESET >AE RESPONS with OSD menu.  
Try to shoot the area as blight as possible, set the ALC volume to Av side, and then, adjust the level volume of lens-side, trying to position the lcursor of IRIS LEVEL to be center.  
After adjusting, restore GAIN and SHUTTER settings to be used. When adjusting blightness, please do not use lens-side volume. Adjsut the blightness with AE LEVEL after the explained adjustment is completed.  
If lens-side volume is forced to use to adjust blightness, AGC and AES would not work properly in conjunction with the other.

9. Factory Settings (Underlined and Bold letters show the factory settings)

OSD Settings

MAIN	GAIN	OFF				
		<u>AGC&gt;</u>	MAX GAIN		<u>36dB</u>	
		MANUAL>	MANUAL GAIN		<u>0dB</u>	
	SHUTTER	OFF				
		FL				
		<u>AES&gt;</u>	LOW SHUTT.LIM.		<u>1/8</u>	
			HIGH SHUTT.LIM.		<u>1/10k</u>	
		MANUAL>	SHUTTER SPEED		<u>1/250</u>	
	WHITE_BAL	<u>ATW&gt;</u>	ATW RANGE		<u>ATW1</u>	
			ATW RES		<u>MID.</u>	
			R OFFSET		<u>128</u>	
			B OFFSET		<u>128</u>	
		3200K				
		4800K				
		6500K				
		MWB>	ONE PUSH	<u>END</u>		
			RED GAIN		<u>128</u>	
			BLUE GAIN		<u>128</u>	
	AESET	LEVEL>	AE LEVEL		<u>64</u>	
		RESPONS>	AGC RES.		<u>32</u>	
			AES RES.		<u>32</u>	
			IRIS RES.		<u>32</u>	
			IRIS LEVEL		-	
		BLC>	BLC SETTING	<u>OFF</u>		
			ON(3x3)			
			ON(USER)>		<u>CENTER(1)</u>	
	OPTION	PICTURE>	SHARPNESS		<u>STD.</u>	
			GAMMA		<u>127</u>	
			CHROMA		<u>192</u>	
			BLEMISH COMP.	OFF		
				USER>	USER COMP.	<u>DISP.</u>
					START LEVEL	<u>16</u>
					MAX. QTY	<u>63</u>
			<u>FACT.</u>			
		EZOOM>	EZOOM		<u>x1.000</u>	
			PAN		<u>128</u>	
			TILT		<u>128</u>	
		DISPLAY>	TITLE	<u>OFF</u>		
				CHAR>		<u>DCC-SC01HD</u> <u>32</u>
			MODE	OFF		
		REMOTE>	BIT RATE	19200bps		
				<u>9600bps</u>		
				4800bps		
				2400bps		
		EXIT	SAVE>			
	CANSEL>					
	DEFAULT>					



10. Dimensions

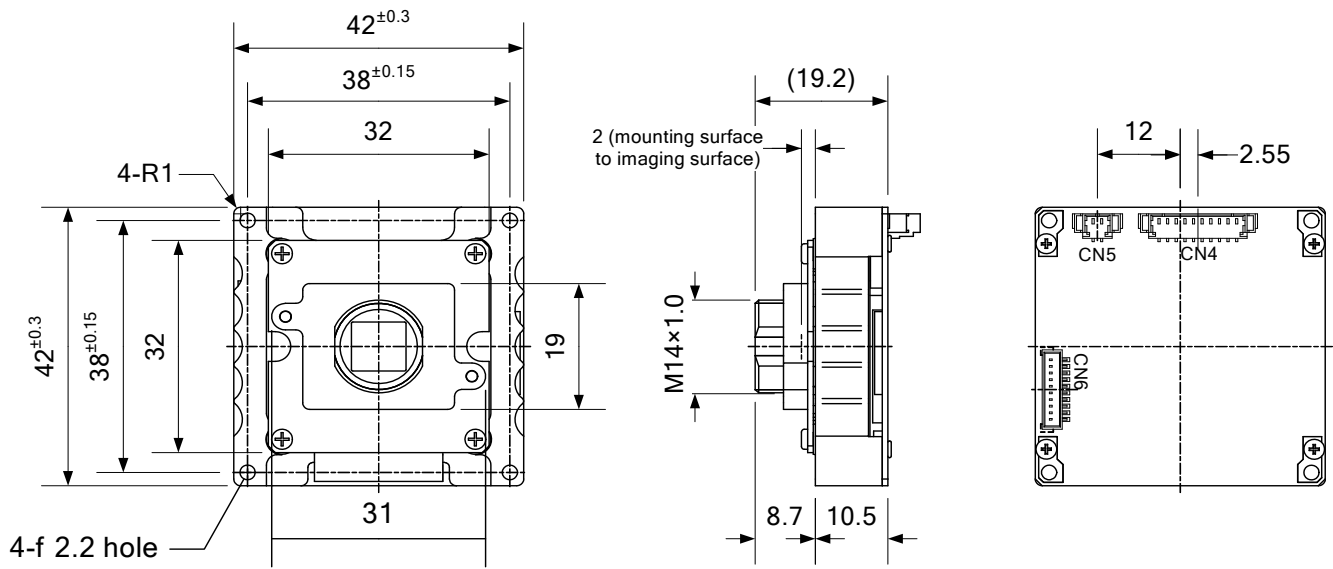

999-540-00-00

(Unit:mm)

#### 11. Cases for Indemnity (Limited Warranty)

We shall be exempted from taking responsibility and held harmless for damage or losses incurred by the user in the following cases.

- In case damage or losses are caused by fire, earthquake, or other acts of God, acts by third party, deliberate or accidental misuse by the user, or use under extreme operating conditions.
- In case indirect, additional, consequential damages (loss of business interests, suspension of business activities) are incurred as result of malfunction or non-function of the equipment, we shall be exempted from responsibility for such damages.
- In case damage or losses are caused by failure to observe the information contained in the instructions in this product specification & operation manual.
- In case damage or losses are caused by use contrary to the instructions in this product specification & operation manual.
- In case damage or losses are caused by malfunction or other problems resulting from use of equipment or software that is not specified.
- In case damage or losses are caused by repair or modification conducted by the customer or any unauthorized third party (such as an unauthorized service representative).
- Expenses we bear on this product shall be limited to the individual price of the product.