



HOT FPA TECHNOLOGY FOR SWAP+C-OPTIMIZED MWIR CAMERA CORE

FLIR Neutrino™ LC

FLIR uncooled LWIR camera cores are synonymous with size, weight, and power + cost (SWaP+C) solutions. The new FLIR Neutrino™ LC is the SWaP+C optimized solution for mid-wave infrared (MWIR) camera cores. Designed as an integral system from the ground up, the Neutrino LC is based on the new FLIR High Operating Temperature (HOT) focal plane array (FPA) technology, is cooled by a new FLIR linear micro-cooler, and uses FLIR Boson™ image-processing electronics. Faster time to image and longer cooler lifetime are key advantages of the Neutrino LC.

Neutrino LC meets the targeted needs of commercial and military markets, specifically the security, EVS, soldier dismount, and UAV verticals. With FLIR product and technical support, OEMs can reduce product development risk and shorten time to market.

www.flir.com/neutrino



SIZE, WEIGHT AND POWER + COST (SWaP+C) OPTIMIZED

SWaP+C optimized MWIR cooled core

- T2SL HOT 640x512/15 μm pixel pitch FPA provides superb imagery, 2x faster time to image, and longer cooler lifetime
- Small and light at 7.4 x 4.5 x 6.1 cm and 370 grams
- Low power consumption with <8 W cooldown and <4 W steady state @21°C
- Rugged construction and wide operational temperature range of -40°C to +71°C
- Quiet and low vibration operation

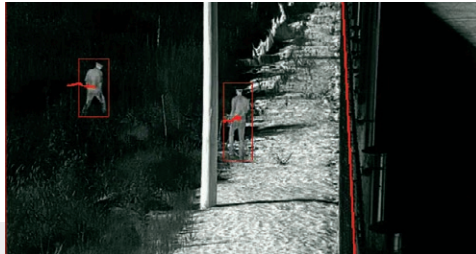

DESIGNED FOR INTEGRATORS

Simplify development and shorten time to market

- Built-in support for physical and protocol-level industry standards (e.g. USB2)
- Full suite of hardware accessories
- FLIR XIR™ expandable infrared video processing architecture and robust SDK
- Classified under US Department of Commerce jurisdiction as EAR 6A003.b.4.a



FLIR VALUE AND REPUTATION

The performance, reliability and support expected from FLIR

- Industry's most advanced SWaP+C optimized image processing
- Increased reliability and low-vibration FLIR linear micro-cooler
- Optional integrated shutter provides faster time to image
- Comprehensive product documentation
- Highly-qualified FLIR Technical Services team available to support integration

SPECIFICATIONS

Neutrino LC

Sensor Technology	HOT MWIR
Sensor Size	640 x 512, 15 μ m pitch
Spectral Band	3.4 to \geq 5.0 μ m Standard
Sensitivity (NE Δ T)	< 25 mK (50% well fill at T _{obj} =30°C flood mode)
Frame Rate Options	60 Hz/50 Hz (NTSC/PAL), 30 Hz/25 Hz (averaging enabled)
Time to Image	< 4 min 23°C ambient

Physical Attributes

Size (L x W x H)	7.4 x 4.6 x 6.1 cm (2.9 x 1.8 x 2.4 in)
f/number	f/5.5 Standard, f/4 & f/2.5 options
Cold Aperture Height	19.7 mm from FPA
Weight	< 380 grams (<13.4 oz)

FPA Control

ROIC	ISC0403
Direct Injections, Snapshot, Progressive	Yes
Programmable Integration Time	Yes (.01 ms – 16 ms)
Well Capacity	7 x 10 ⁶ electrons
Frame Rate	60 Hz, programmable up to 60 Hz
ROIC Modes	Free Run, Readout Priority, & Integration Priority
External Sync	Master or Slave

Image Processing & Display Controls

NTSC/PAL	Yes (accessory board required)
Image Optimization/AGC	Linear, Histogram Equalization, DDE
Invert/Revert	Yes
Color Palettes/LUTs	Yes, RGB888 mode
Symbology	Yes, RGB888 mode
Continuous Zoom	Yes, up to 8x

Digital Video

Parallel (24-bit/16-bit/8-bit)	Yes
Camera Link	Yes (accessory board required)
USB	Yes

Interfacing

Primary Electrical Connector	80-pin Hirose, DF40C-80DS
Input Power	+3.3 VDC Camera, +12 VDC Cryocooler
Power Dissipation	<8 W cooldown, <4 W steady state @ 23°C
Communication	USB or UART (921.6k baud)
Discrete I/O Control	One Discrete, custom configurable at factory
User Configurability via SDK & GUI	Yes

Specifications are subject to change without notice.
For the most up-to-date specs, go to www.flir.com

Environmental

Operating Temperature Range	-40°C to +71°C (-40°F to +160°F)
Non-Operating Temperature Range	-54°C to +80°C (-65°F to +176°F)
Operational Altitude	40,000 ft (~12 km)
Humidity	Non-condensing between 5% – 95%
Vibration	5.8 grms 3-axis, 1 hr each
Shock	40g pulse w/1 ms half-sine pulse, 3-axis (goal)

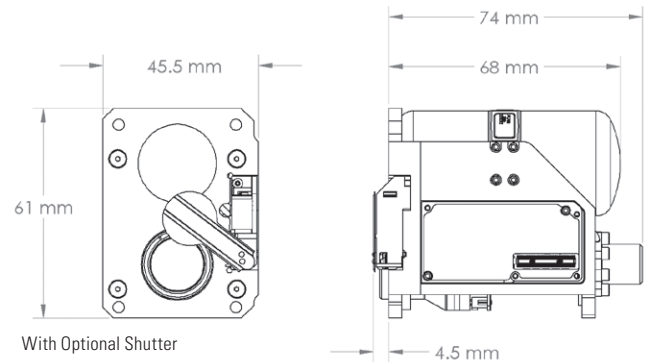
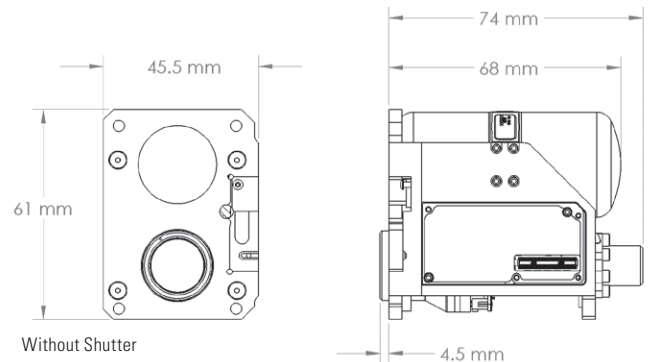

CORPORATE HEADQUARTERS
FLIR Systems, Inc.
27700 SW Parkway Ave.
Wilsonville, OR 97070
PH: +1 877.773.3547

SANTA BARBARA
FLIR Systems, Inc.
6769 Hollister Ave.
Goleta, CA 93117
PH: +1 805.690.6602

This document has been provided by:



For FLIR Sales and Service contact us at:

Phone: 1-888-919-2263 | Outside the U.S.: +1-845-343-4077 | Fax: +1-845-343-4299

Address: P.O. Box 4242 Middletown, New York 10941 USA

www.flir.com
NASDAQ: FLIR

Equipment described herein is subject to US export regulations and may require a license prior to export. Diversion contrary to US law is prohibited. Imagery for illustration purposes only. Specifications are subject to change without notice. ©2018 FLIR Systems, Inc. All rights reserved. Revised 12/07/18

18-1490-OEM-COR-Neutrino-LC-Data-Sheet LTR



The World's Sixth Sense®